

Puntoni dei "cavalletti" trasversali

Sviluppo dei puntoni tubolari di raccordo tra impalcato e briglie inferiori

Tipo acciaio: S355J0
Scala: 1:10

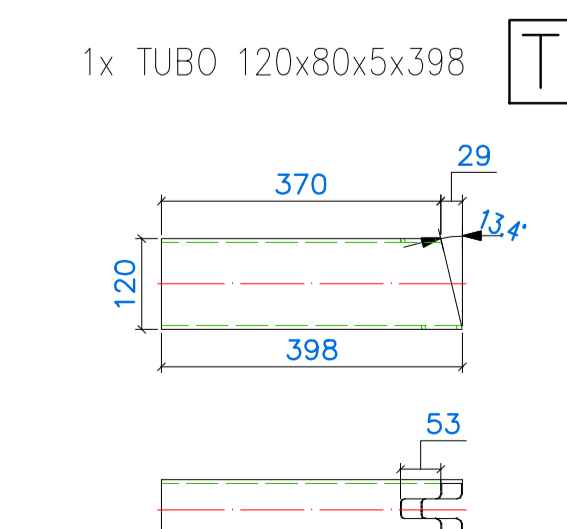
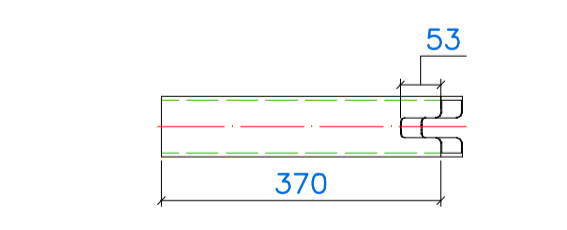
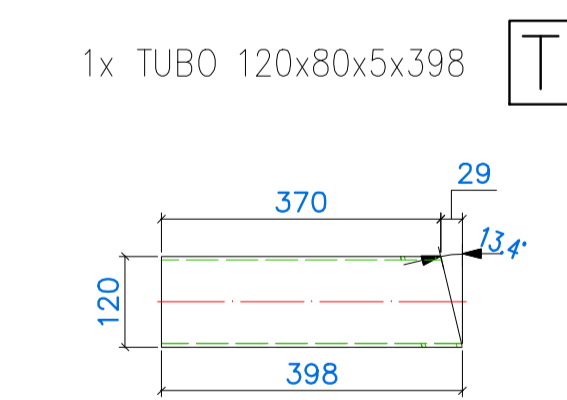
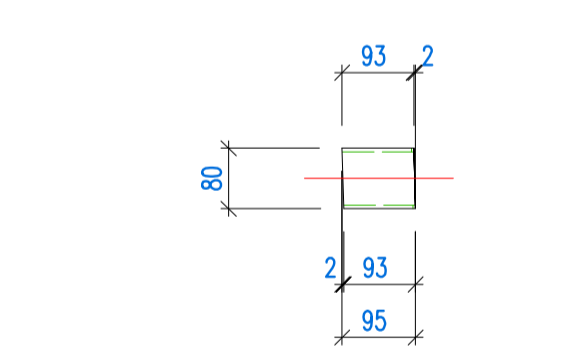
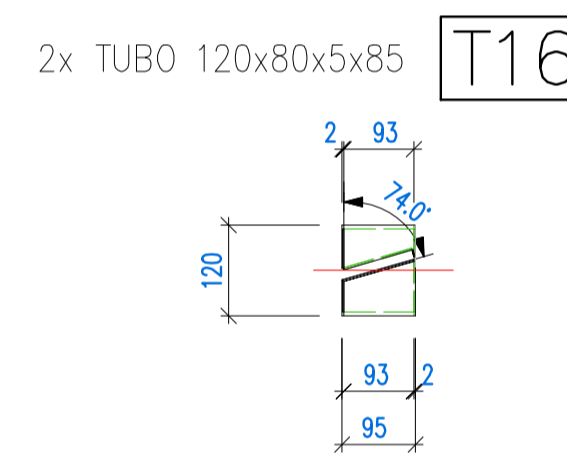
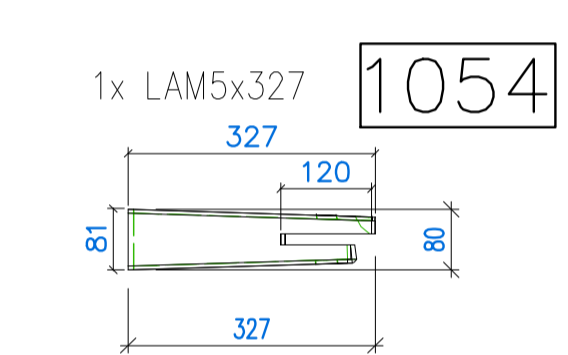
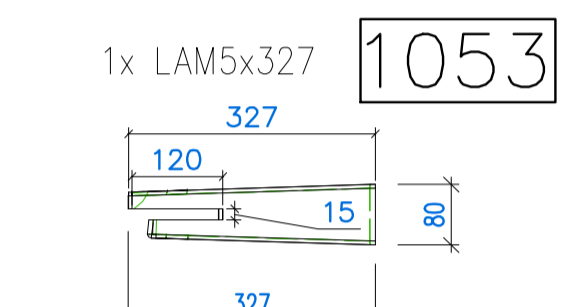
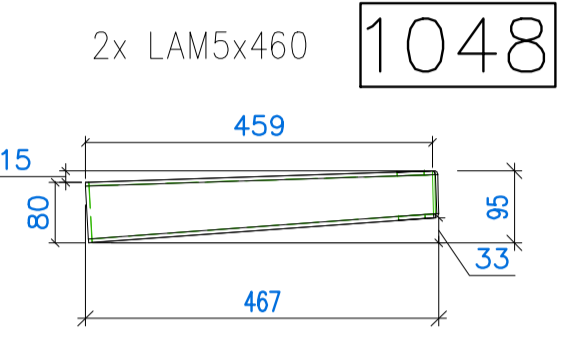
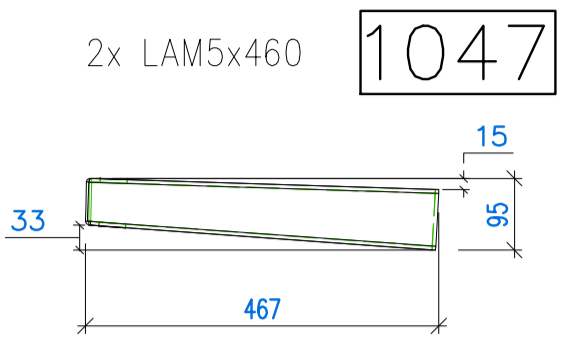
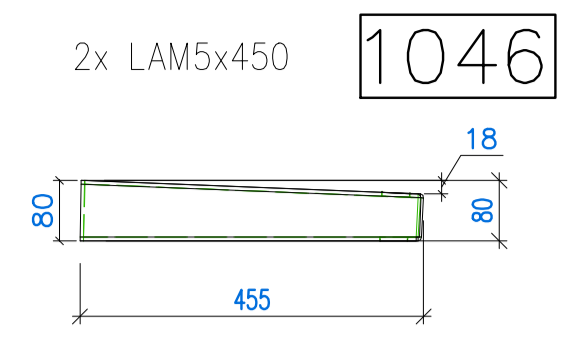
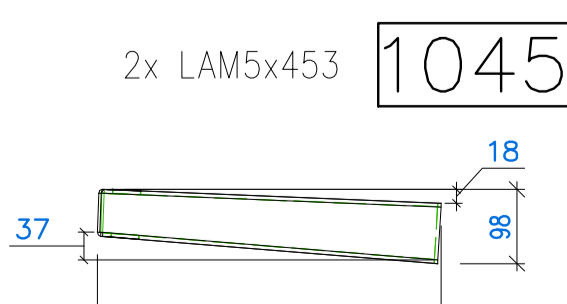
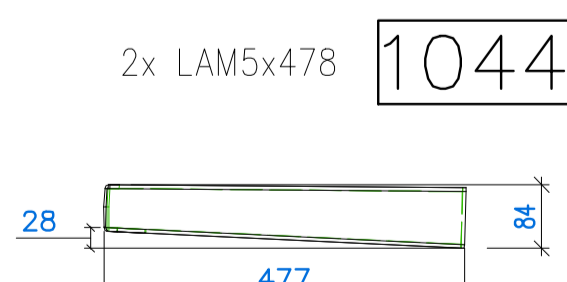
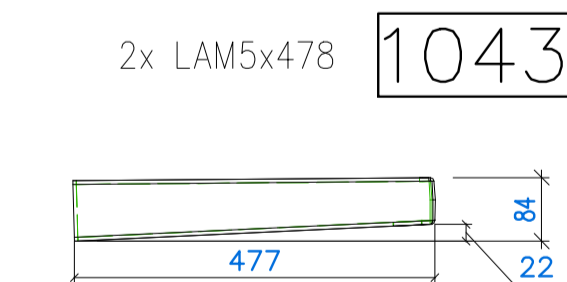
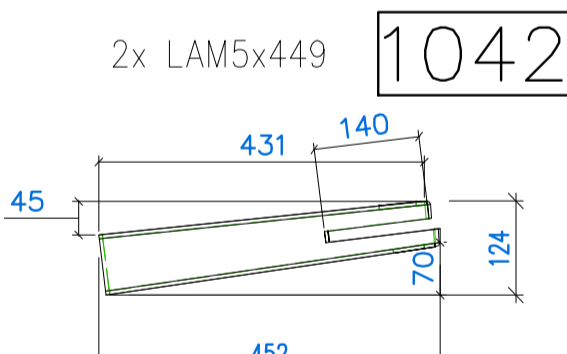
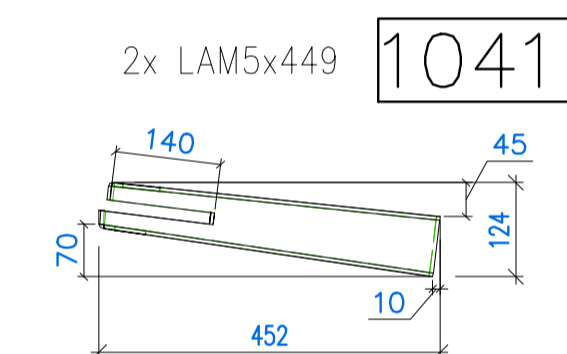
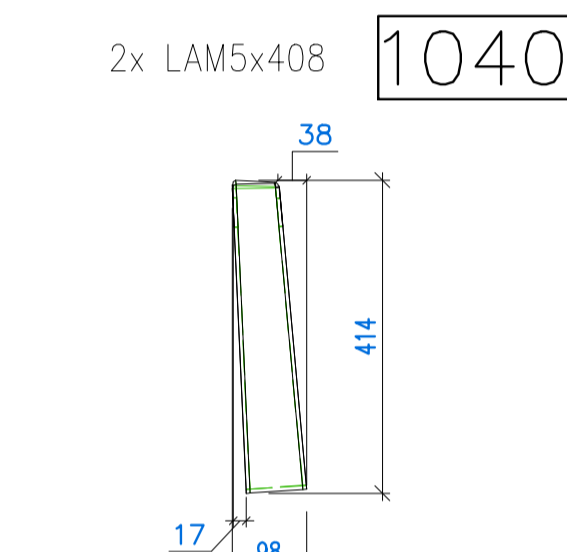
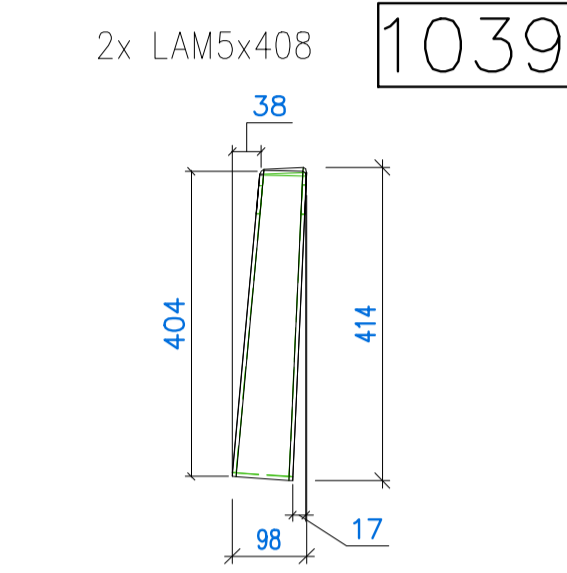
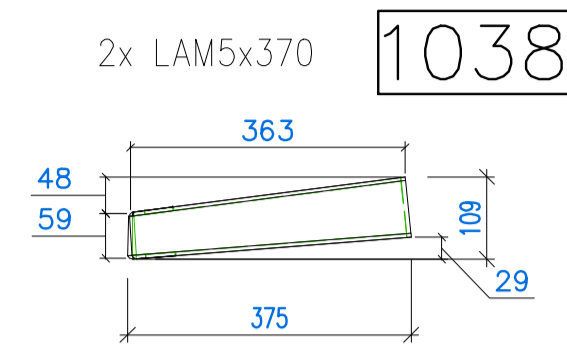
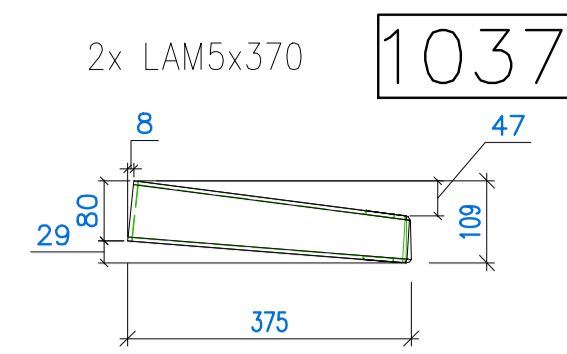
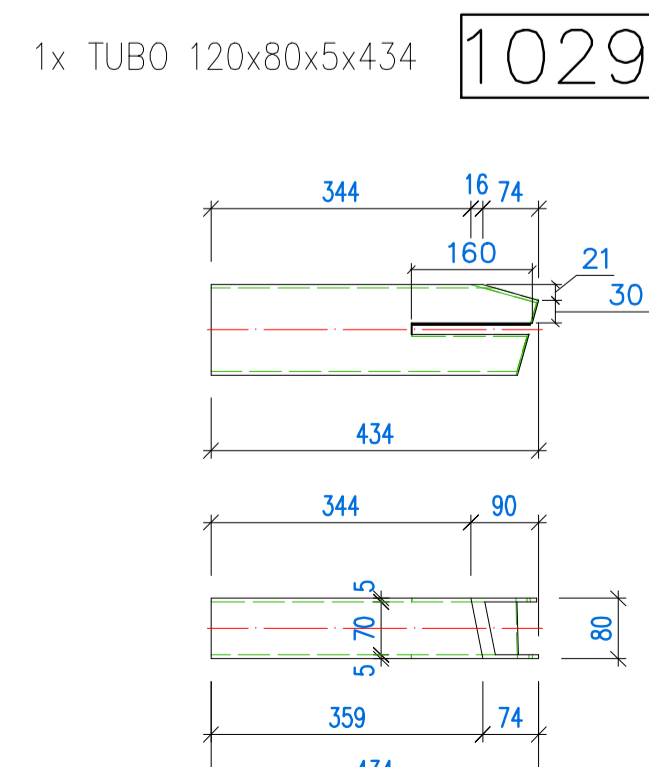
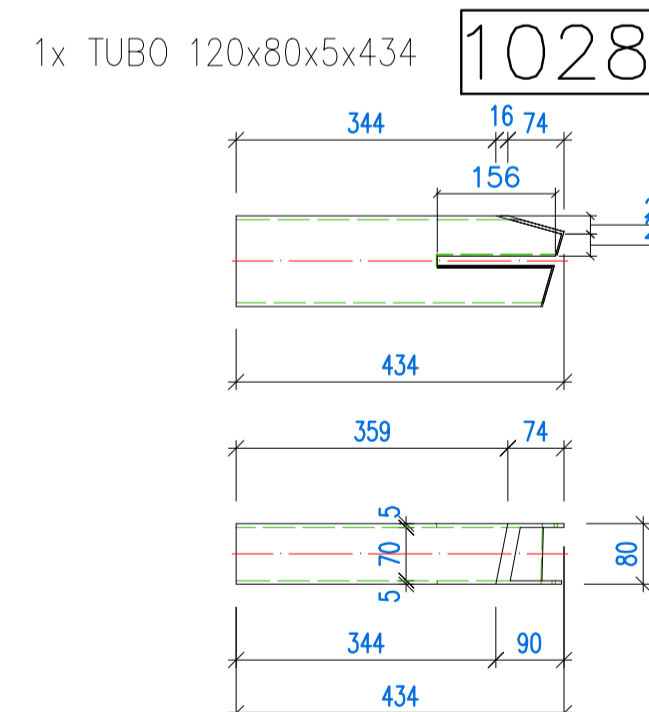
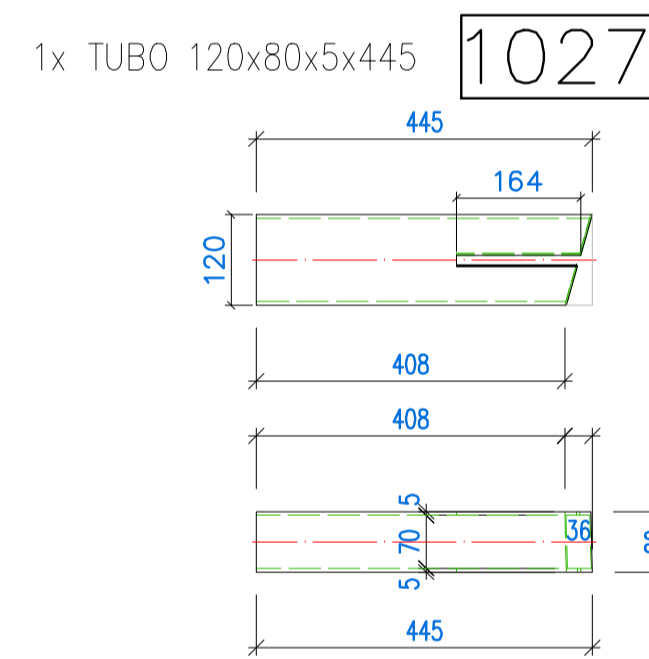
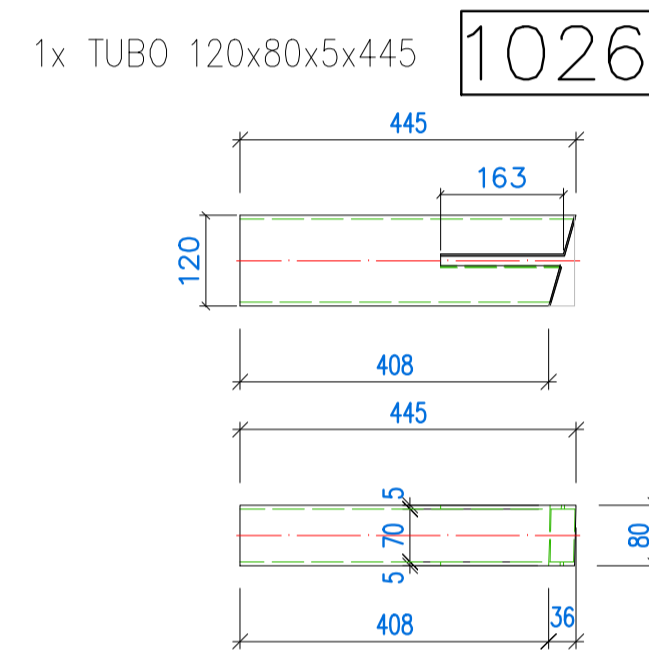
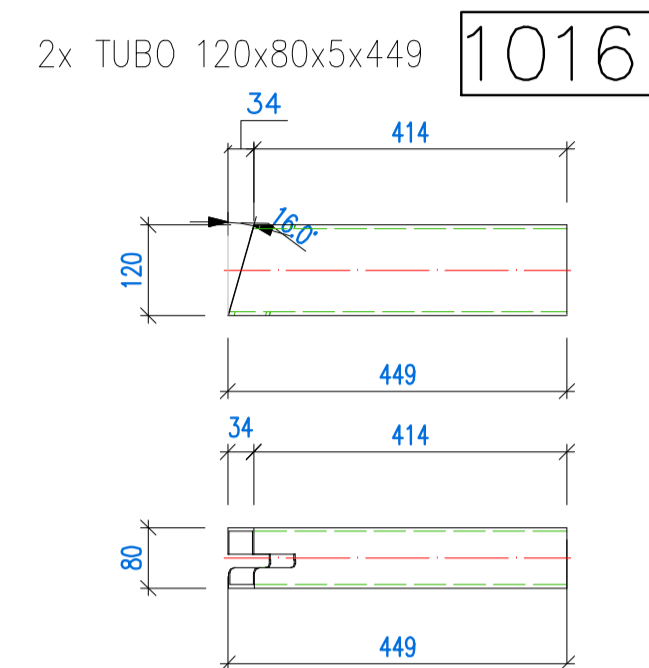
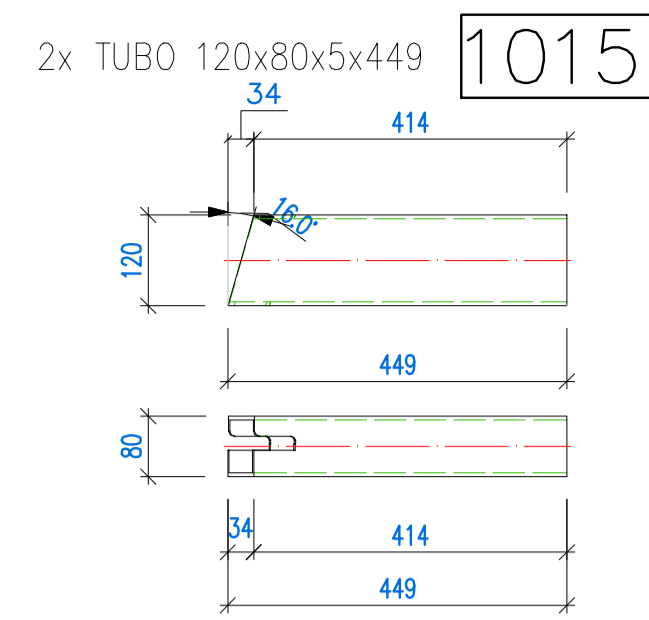
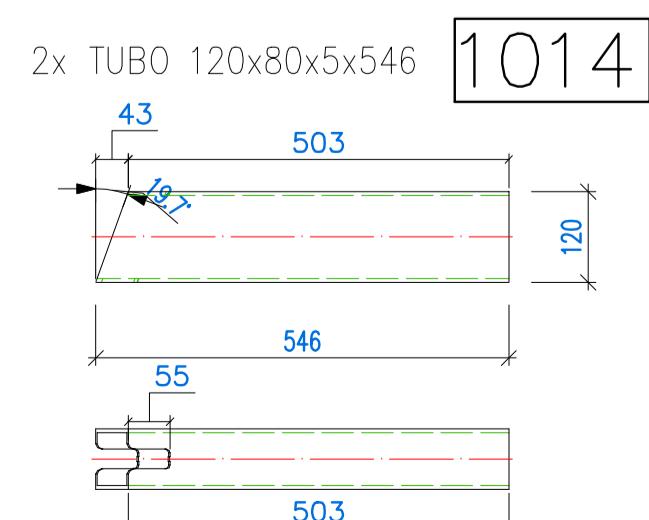
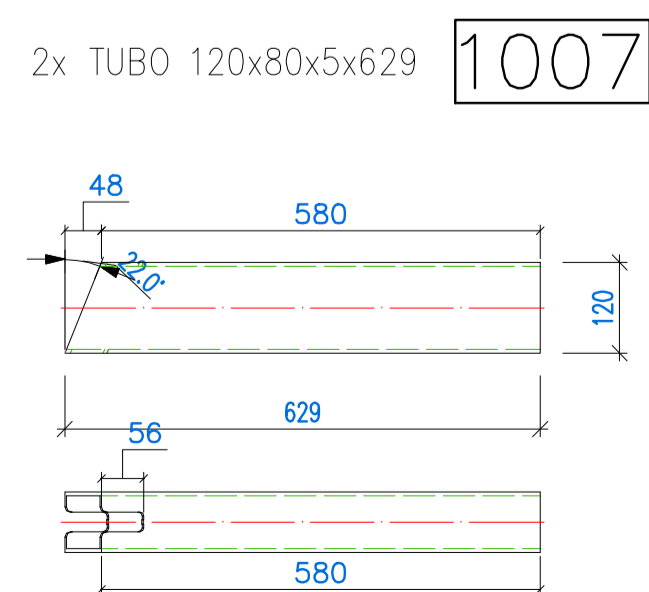
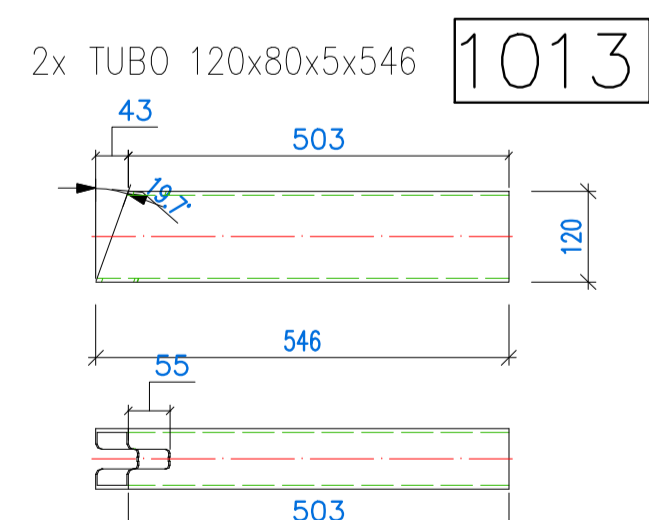
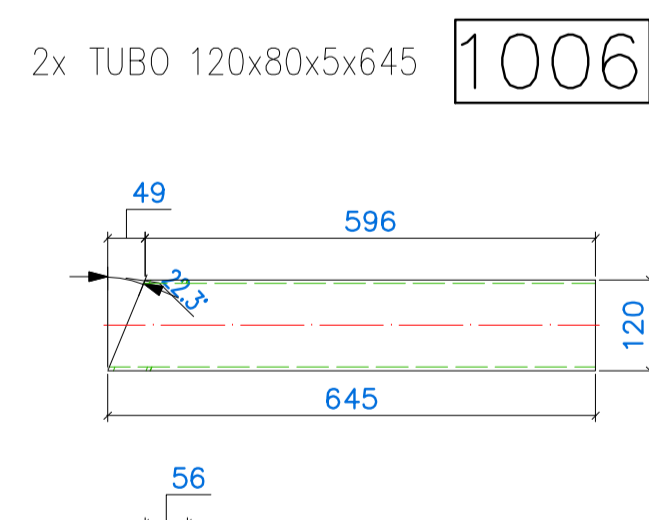
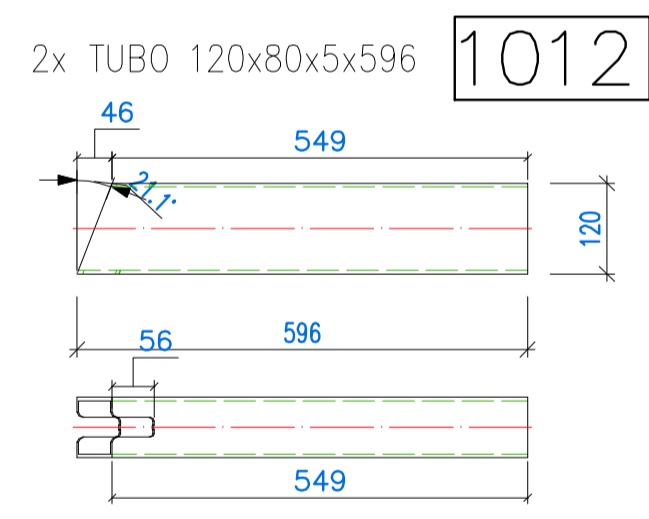
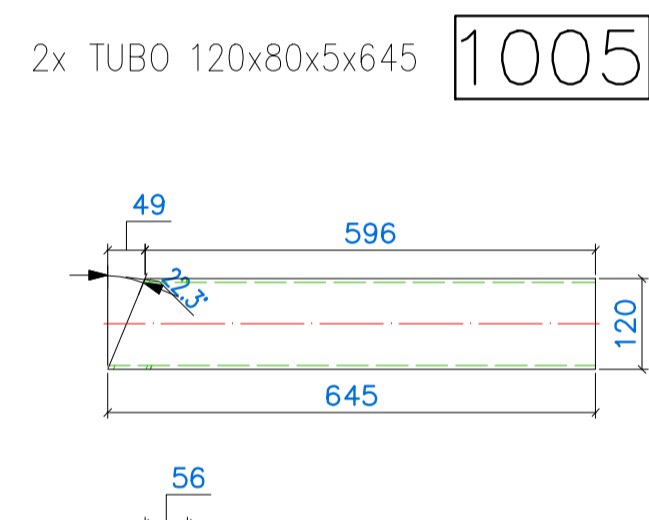
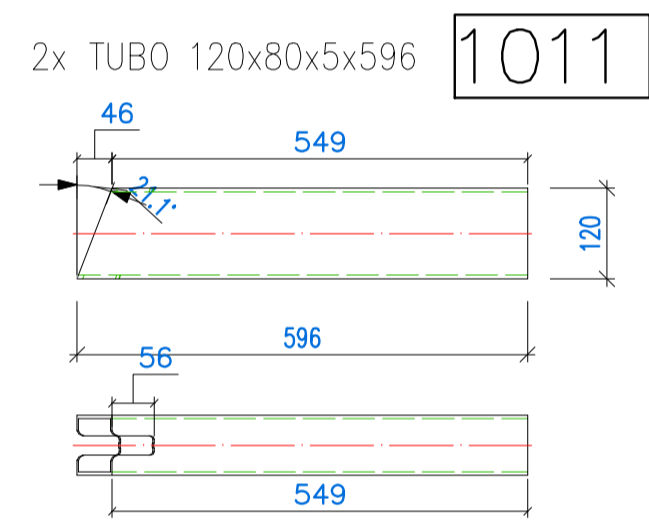
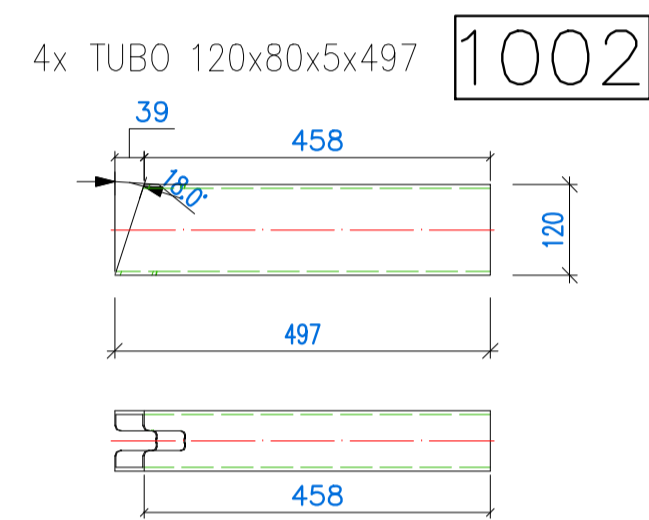
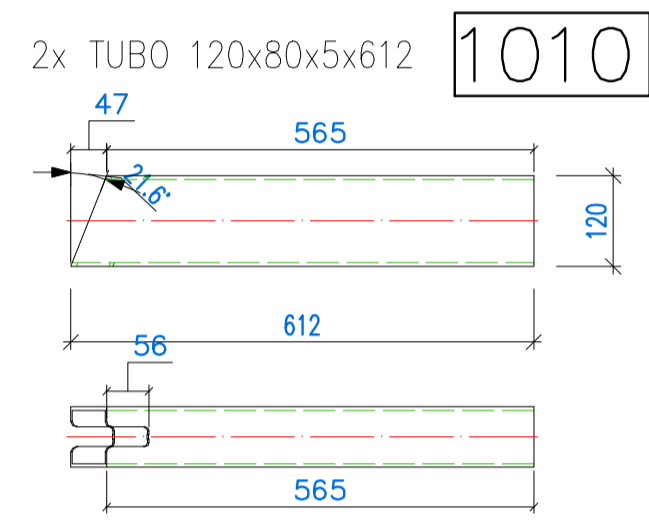
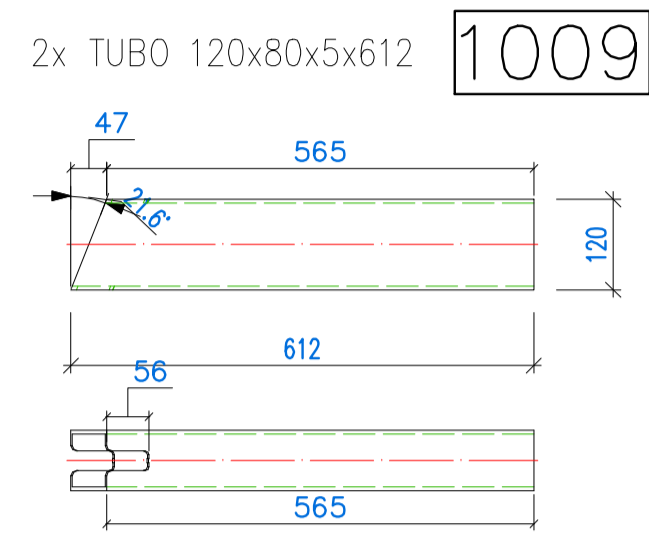
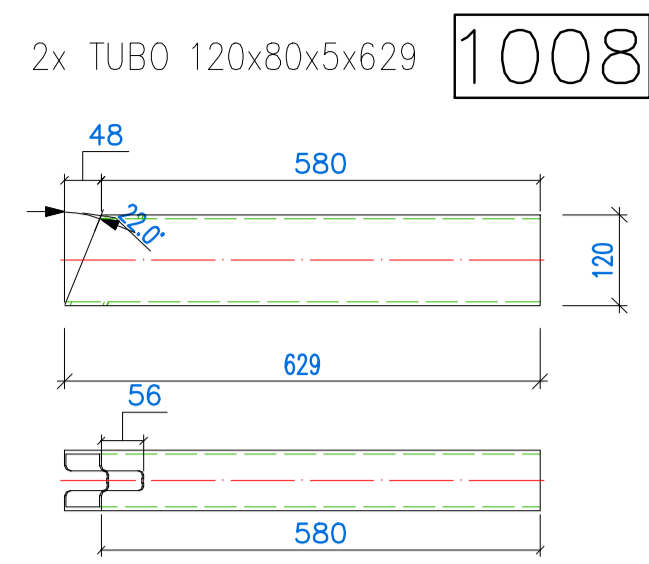

NOTA SULLE SALDATURE: In mancanza di diverse indicazioni le saldature dovranno essere realizzate in continuo su tutti gli spigoli di contatto, a cordone d'angolo o a completa penetrazione (a seconda dei dettagli di nodo)

Prima di procedere con l'esecuzione delle carpenterie, sarà onere dell'impresa verificare le misure direttamente in cantiere.

MATERIALI (ove non specificato diversamente):	
Bulloneria: Ad 2010 resistenza classe 8.8 (punt. 11.3.4.4 - DM. 12/01/2018) (UNI EN 15048-1:2007)	<ul style="list-style-type: none"> ◆ foro #13 per M12 ◆ foro #15 per M14 ◆ foro #17 per M16 ◆ foro #19 per M18 ◆ foro #21 per M20 ◆ foro #23,5 per M22 ◆ foro #25,5 per M24 ◆ foro #28,5 per M27 ◆ foro #31,5 per M30
<ul style="list-style-type: none"> — composizione: 1 vite + 2 rondelle + 1 dado MT: 6-8 secondo UNI EN ISO 898-1:2001 DADE: 6-10 secondo UNI EN 20898-2:1994 ROSETTE: Acciaio C50 UNI EN 10083-2:2006 temprata e rinvenita NRC 32/40 PIASTRINE: Acciaio C50 UNI EN 10083-2:2006 temprata e rinvenita NRC 32/40 	<p>Profilati e Lamiere: Acciaio: S235J0-S275J0-S355J0J0 PROFILATI/LAMIERE secondo UNI EN 10025 PROTEZIONE: ZINCATURA A CALDO</p> <p>SALDATURE A CORDONI D'ANGOLO SECONDO IL SEGUENTE SCHEMA: M18 coppia di serraggio 309 Nm $t_f < t_1$, $a = 1,0 t_1$ (punt. 4.2.8.2 e 11.3.4.5 del DM. 12 gennaio 2018)</p> <p>SALDATURE A COMPLETA PENETRAZIONE SECONDO IL SEGUENTE SCHEMA: M27 coppia di serraggio 1110 Nm M30 coppia di serraggio 1508 Nm $d = 1,3 t$ (punt. 4.2.8.2 e 11.3.4.5 del DM. 12 gennaio 2018)</p>

Finanziato dall'Unione europea NextGenerationEU
Comune di Certaldo

Ing. Giovanni Corti
INGEGNERE CIVILE
1 0577 93743 | C. 388 #90168 | e-mail info@giovannicorti.com | pec: giovannicorti@ngpec.eu
Via Monte Sobbolito n. 40 - 53036 FOGGIONINI (SI) | CR. CNG-458/2407202 | P.Iva 03914790229



PROGETTO:			
INTERVENTO DI ADEGUAMENTO STATICO E SISMICO DELLA PASSERELLA PEDONALE SUL TORRENTE AGLIENA TRA VIA TRENTO E VIA B. CIARI			
Progetto ESECUTIVO			
COMUNE	Certaldo	SCALA	1:10
LOCALITA'	Via B. Ciari - Via Trento	DATA	Marzo 2022
STAZ. APPALTANTE	Comune di Certaldo	TAV.	
ELABORATO	IMPALCATO Campata "A" - Dettagli degli elementi metallici Puntoni dei "cavalletti" trasversali	S24	
STAZ. APPALTANTE	COMSTRUTTORE		
Comune di Certaldo		Ing. Giovanni Corti	